

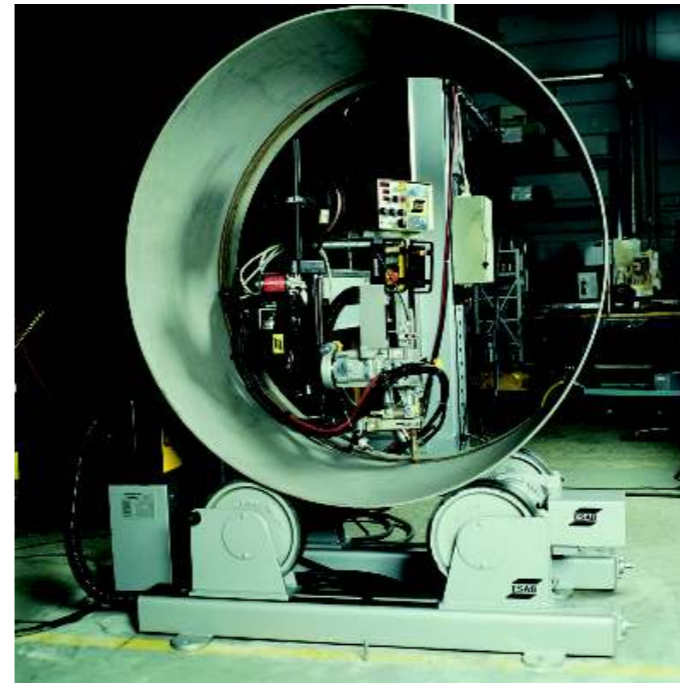

2 6



02140 . . . 9A
. 8 10 (38044) 501 23 24
8 10 (38044) 575 21 88
E-mail: info@esab.com.ua



www.esab.ru, www.esab.com

2 Multitrac
2 Mini Master

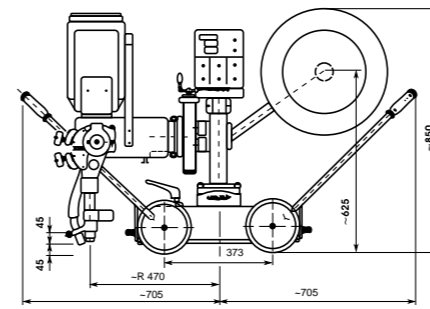
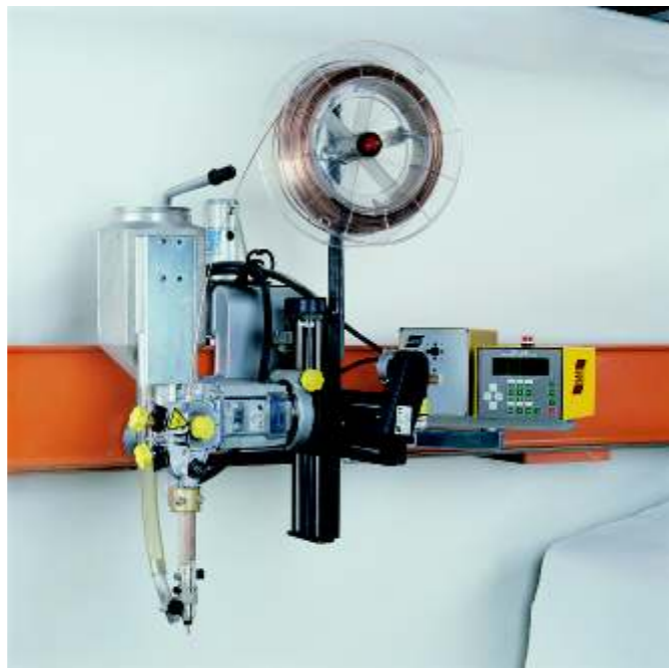

Mastertrac

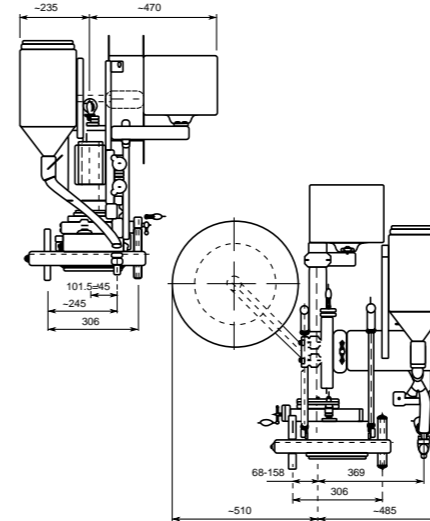

Mastertrac



6 Singlen Mastertrac SAW	0456 486 880
6 Singlen Mastertrac MIG/MAG	0456 485 880
6 Tandem Mastertrac	0456 755 880
	0334 291 889
	0334 291 888
	0153 872 880
	0146 967 880
	0334 299 880
	0155 972 880
	0671 161 880
	0156 025 001
	0153 592 880
	0254 900 880
	0254 900 301
	0671 171 580
	0153 143 885
	0148 140 880
	0333 164 880
	0671 125 780
	0154 203 880

6 Mastertrac

100%	1500	600	1500	2x1500
	3,0-6,0	1,0-3,2	2x2,0-3,0	2x2,0-6,0
	0,2-4,0	0,2-16,6	0,2-4,0	0,2-4,0
	0,1-2,0	0,1-2,0	0,1-2,0	0,1-2,0
	42	42	42	42
	30	30	2x30	2x30
	10	---	10	10
	110	100	110	158

Y=		Ligh Duty ()				Tandem	
6 ¹⁾	1,0	0153 501 004					
	1,2	0153 501 005					
	1,6	0153 501 007					
10	1,6	0258 000 909					
	2,0	0258 000 910					
	2,4	0258 000 911					
	3,2	0258 000 915					
	6/ 10	0147 333 001					
		D20					
12	1,6	0154 623 008	Y				Y
	2,0	0154 623 007	Y				Y
	2,5	0154 623 006	Y				Y
	3,0	0154 623 005	Y				Y
	4,0	0154 623 003	Y				Y
		D35					
	3,0	0265 900 880					X
	4,0	0265 900 882					X
	5,0	0265 900 883					X
	6,0	0265 900 884					X
		Light Twin					
6	2 1,2	0153 501 005				Y	
	2 1,6	0153 501 007				Y	
	2 2,0	0153 501 009				Y	
		Heavy Twin					
	2 2,0	0153 501 005					X
	2 2,5-						
	3,0	0153 501 007					X
	1,0	0145 538 882					
	1,2	0145 538 883					
	1,6	0218 510 281	Y				
	2,0	0218 510 282	Y				
	2,4-2,5	0218 510 283	Y				
	3,0-3,2	0218 510 298					
	4,0	0218 510 286					
	5,0	0218 510 287					
	6,0	0218 510 288					
	1,2-1,6	0146 024 880	Y				Y
	2,0-4,0	0146 024 881					X
	1,2-1,6	0146 025 880	Y				Y
	2,0-4,0	0146 025 881					X
	2 1,2	0218 522 486				Y	
	2 1,6	0218 522 488				Y	
	2 2,0	0218 522 484				X	
	2 2,5	0218 522 480				X	
	2 3,0	0218 522 481				X	

2 Multitrac

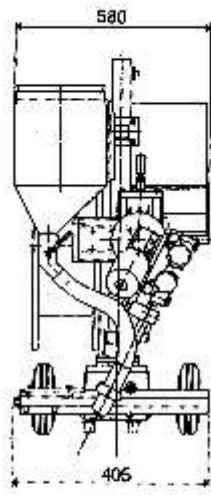
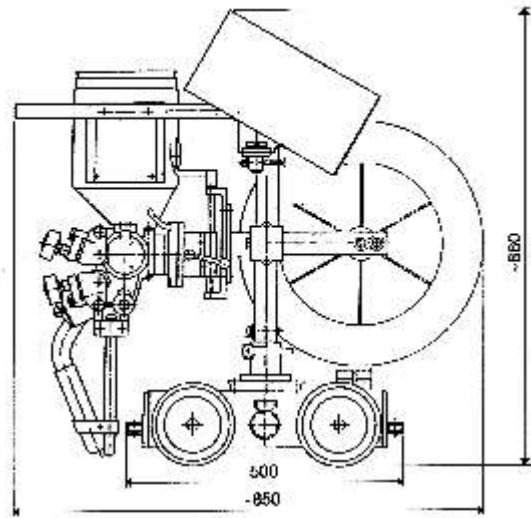

2 Multitrac SAW -	0449160880
2 Multitrac GMAW - /	0449161881
	0449160881
	0457897880
	0145203880
,30	0153872880
,30	0416492880
,220	0413526881
/	0333098881
V-	

	1,6-4,0	2X1,2-2,5	0,8-1,6
	1,6-4,0		0,8-1,6
	---	---	1,2-2,4
(/)	>9	>9	>16
()	30	2X15	30
	6	6	---
100% ()	47	45	43
	800	800	600
()	42	42	42
(/)	0,1-1,7	0,1-1,7	0,1-1,7
()	90	90	90

12	
1,6	0154 623 008
2,0	0154 623 007
2,5	0154 623 006
3,0	0154 623 005
4,0	0154 623 003
6	
0,8	0153 501 002
1,0	0153 501 004
1,2	0153 501 005
1,6	0153 501 007
2,0	0153 501 009
2,4-2,5	0153 501 010
10	
1,6	0258 000 909
2,0	0258 000 910
2,4	0258 000 911
3,2	0258 000 915
6/ 10	0147 333 001
0,8	0145 538 881
1,0	0145 538 882
1,2	0145 538 883
1,6	0218 510 281
2,0	0218 510 282
2,4-2,5	0218 510 283
3,0-3,2	0218 510 298
4,0	0218 510 286
1,2-1,6	0146 024 880
2,0-4,0	0146 024 881
0,8-1,6	0146 025 880
2,0-4,0	0146 024 881
	0212 901 101
2 1,2	0218 522 486
2 1,6	0218 522 488
2 2,0	0218 522 484
2 2,4-2,5	0218 522 480
	0413 542 880
	0333 164 880
	0333 098 881
V-	0154 203 880
,3	0153 143 886
	0457 788 880
	0148 140 880
	0332 947 880
	0414 191 881
2 220 V, 50/60 Hz	0190 270 101
	0190 315 105
	0334 689 880
	0334 680 881

6

6

6 Mastertrac
6 Arc Master

6

3 6
100

1250

1600

TAF

LAF

6 Arc Master

6 Mastertrac

Mastertrac c

6 Tandem Mastertrac

()

()

A6 Single Mastertrac

A6

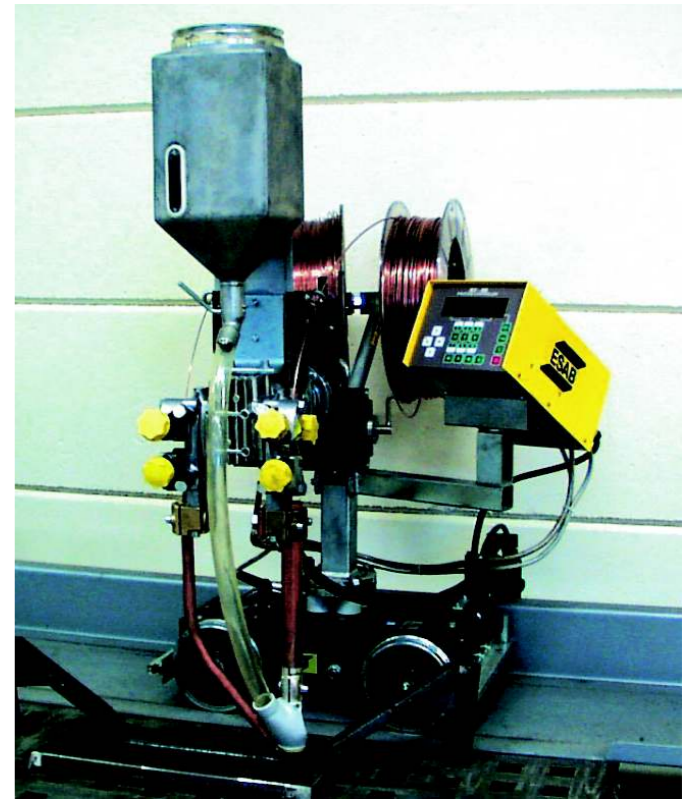

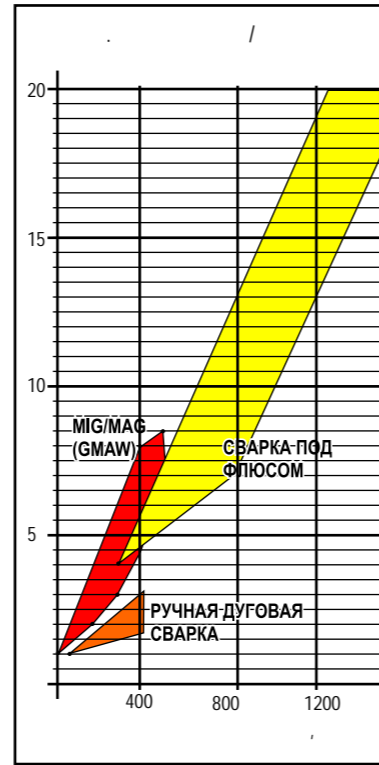

2/ 6
 - A6 LD
 - A6 HD
 A6 HD

- A6 G
 "G"

0,5 30-100

PAK

"G"

6.

6,

2/ 6

2,

LAF TAF.

- Basic
 - Super
 -FFRS -

MKR, CAB, MechTrac
 MKR 300

4 4
 CAB

MechTrac

2 2

2

8 10

3-5

- 150



6

1500

: PAK GMD.

GMD,

GMD

GMD

LAF TAF.

2/PEI
 PEI

MKR CAB

LAF TAF
 LAF
 LAF
 /
 TAF



(100%)